

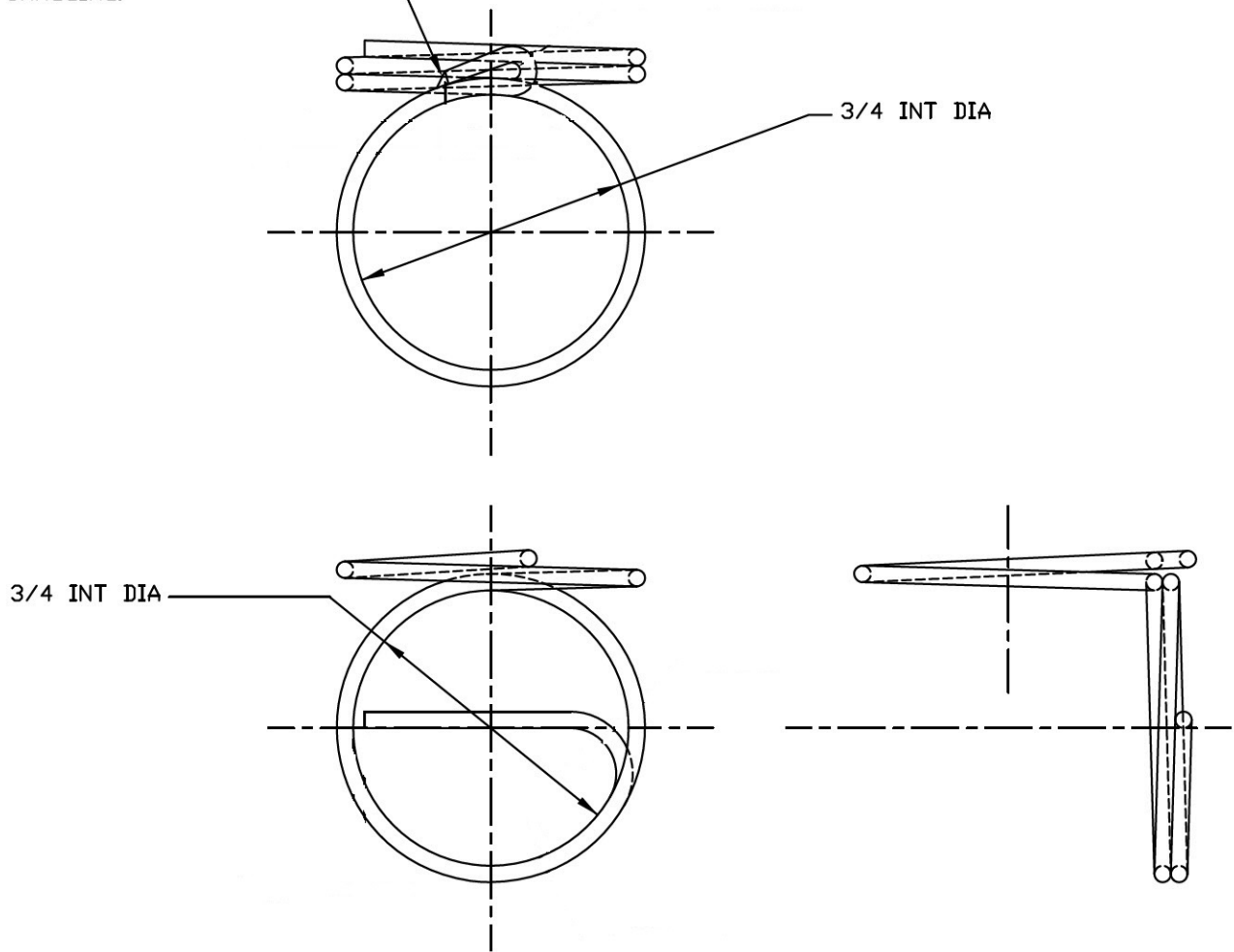

CLOSE THIS END AS SHOWN.  
 BRAZE END TOGETHER.  
 DO NOT REMOVE SPRING  
 TEMPER FROM MORE  
 THAN LAST QUARTER  
 TURN. GRIND END FLUSH  
 AND SMOOTH WITH EDGE  
 OF WIRE TO PREVENT  
 SNAGGING.



ADAPTED 1/7/98, REVISED (A) 4/28/05, REVISED (B) 8/29/09, REVISED (C) 4/24/14.

**Parachute Industry Association**



DISTRIBUTION STATEMENT:  
 All Rights Reserved. No part of this  
 publication may be reproduced without  
 written permission from the Parachute  
 Industry Association. Additional copies  
 may be purchased on-line from the  
 PIA Store at [www.pia.com](http://www.pia.com)

Title  
**RETAINER-SNAP  
 PARACHUTE LANYARD**

PIA  
 Standard  
**PS27767**

Procurement Specification  
 PIA-H-7195 (B2) (C1)

Adopted From:  
 MS27767

Sheet 1 of 3 (B1)