



**PIA Technical Bulletin TB-241**  
**Parachute Industry Association Publications**  
March 2, 2000

---

Container Grommets and Small Suspension Lines

Because of two recent fatalities involving relatively small suspension lines snagging on container grommets, as well as other similar incidents not resulting in fatalities, the PIA Technical Committee recommends:

- 1) All container grommets should be inspected to ensure that they are properly set. See figure 1.
- 2) On main containers with a “main closing loop webbing anchor”, users/riggers should contact the manufacturer for their current recommendations. See Figures 2 and 3.
- 3) Because of design specific issues, PIA further requests that all equipment manufacturers individually address these issues and disseminate relevant information to the field.

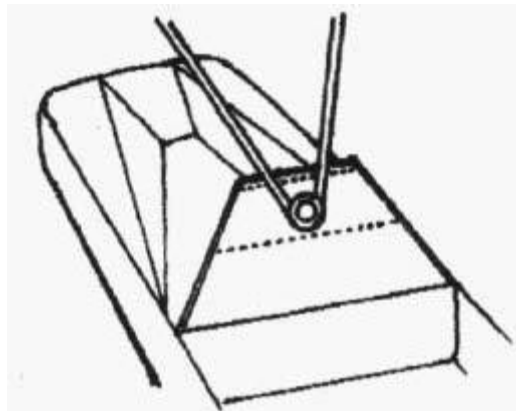

Figure 1 -Suspension-line snagged around improperly seated container flap grommet.

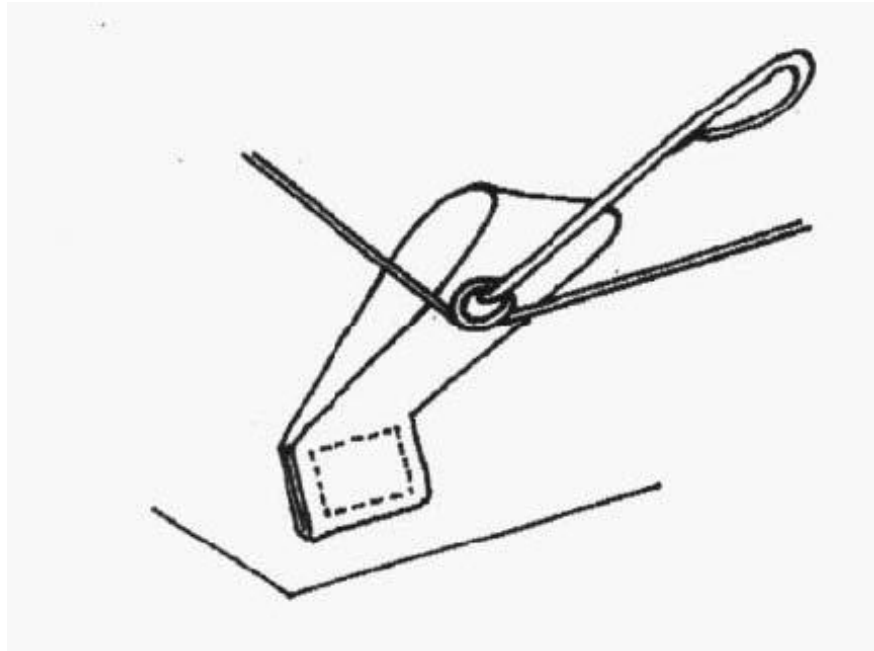

Figure 2 - Suspension line snagged around grommet on main loop anchor

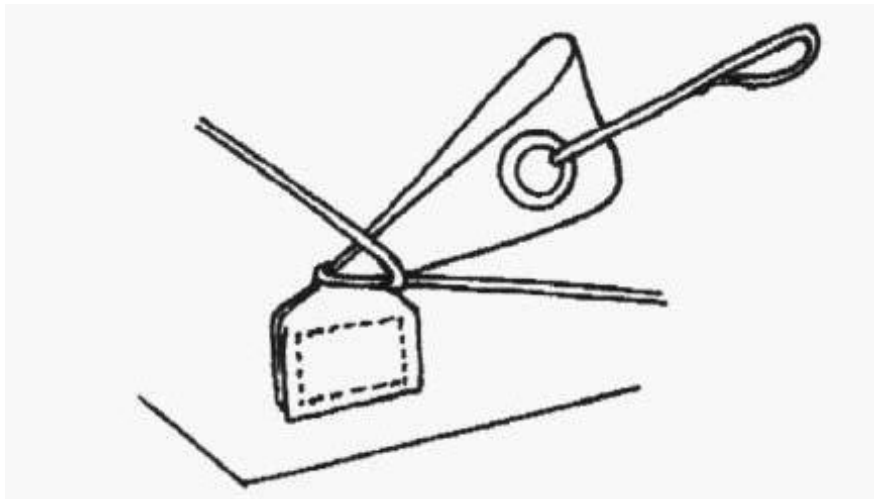

Figure 3 - Suspension line half-hitched about main loop anchor